

# PressCam 8 Junior

## Installation & Operations Manual



### SAFETY INSTRUCTIONS



#### **WARNING**

Read and fully understand this manual. Failure to do so could result in death or serious injury.



**Pressroom** *Electronics*™



**DANGER** indicates a hazardous situation which, if not avoided, will result in death or serious injury.



**WARNING** indicates a hazardous situation which, if not avoided, could result in death or serious injury.



**CAUTION** indicates a hazardous situation which, if not avoided, could result in minor or moderate injury.



**NOTICE** is used to address practices not related to physical injury.



**Safety Instructions** (or equivalent) signs indicate specific safety-related instructions or procedures.

# Machinery Guards and Controls

✓ for  
info

- Punch Press Controls** (Resolver or Rotary Cam Based)
- Punch Press Automation Controllers**
- Time-Based Brake Monitors**
- Mute-out Packages**
- Components & Accessories**
- Brake Performance Tester**
- PressCam 8-“Control Reliable” Punch Press Automation Controller**

Please send me information on the above marked items

Name:	_____
Title:	_____
Company:	_____
Address:	_____
	_____
City, State, Zip:	_____
Phone:	_____
Fax:	_____
Email:	_____

Fax your request to 412-262-1197



P.O. Box 99875, Pittsburgh, Pennsylvania 15233  
800-937-4334 412-262-1115 FAX: 412-262-1197

sales@pressroomelectronics.com    www.pressroomelectronics.com

**[www.pressroomelectronics.com](http://www.pressroomelectronics.com)**

# PressCam 8 Junior

## Installation and Operation Manual

**Pressroom Electronics, Inc.**  
3715 Swenson Avenue  
St. Charles, IL 60174

P/N: 28-038r3-6

Customer Service: 630-443-9320 (CST)  
(Please have Model #, Serial #, and Software Rev # Available)

Sales and Marketing: 800-937-4334 (EST)

## Proper Usage and Warnings

**⚠️ WARNING** The information disclosed herein includes proprietary rights of the manufacturer. Neither this document nor the information disclosed herein shall be reproduced or transferred to other documents, used or disclosed to others for manufacturing purposes, or for any other purposes, except as specifically authorized in writing by the manufacturer. If this manual is supplied in connection with the sale or delivery of manufacturer's equipment, it is to be used solely for maintenance, repair or installation of such equipment.

You **MUST** read and fully understand the following information pertaining to the proper use and limitations of your PressCam 8 Junior:

- The PressCam 8 Junior **MUST** be installed by qualified personnel only.
- The PressCam 8 Junior **MUST NOT** be used on full revolution presses or any machine that cannot be commanded to stop at any time.
- The press on which the PressCam 8 Junior is installed **MUST** meet OSHA 1910.217 regulations which include inspection and maintenance procedures that **MUST** be followed to meet these regulations. And is highly recommended that the press meet current ANSI B11.1-2009 standards. The manufacturer **WILL NOT** take responsibility for improperly maintained machinery.
- The PressCam 8 Junior **MUST** be checked out before put into use, follow this manual for the proper procedures.
- The PressCam 8 Junior **SHALL NOT** be modified or repaired except by qualified personnel and/or upon authorization of the manufacturer. Never operate machinery that is not in full working order.
- Make sure that all maintenance people, machine operators, die-setters, foremen, and supervisors have read and understand this manual.
- All procedures in this manual **MUST** be followed. The manufacturer **WILL NOT** take responsibility for operation if all procedures and warnings listed in all manuals are not followed.

## Warranty

Manufacturer warrants that this product will be free from defects in material and workmanship for a period of two years from the date of shipment thereof. Within the warranty period, manufacturer will repair or replace such products which are returned with shipping charges prepaid and which will be disclosed as defective upon examination by the manufacturer. This warranty will not apply to any product which will have been subject to misuse, negligence, accident, restriction, and use not in accordance with manufacturer's instructions or which will have been altered or repaired by person's other than the authorized agent or employees of the manufacturer.

## Disclaimer

The provisions of the paragraph "WARRANTY" are the sole obligations of the manufacturer and exclude all other warranties of merchantability, expressed or implied.

Further, there are not warranties which extend beyond the above warranty.

## Limitation of Liability

In the event of any claim for breach of any obligations of manufacturer under any order, whether expressed or implied, and particularly in the event of any claim of a breach of the warranty or warranties contained in the paragraph "WARRANTY" or of any other warranties, expressed or implied which might despite the paragraph entitled "DISCLAIMER," be determined to be incorporated in any order, the company shall under no circumstances be liable for any consequential or special damages, either in law or in equity, or for losses or expenses or claims for the same arising from the use of, or inability to use, the products of the manufacturer for any purpose whatsoever.

This equipment has been designed to the very highest performance and safety standards known to the current technological state of the art. However, the installation, usage, suitability, and fitness of our equipment for any purpose, known or unknown, is interdependent upon the performance of other equipment not manufactured, installed, or secured or maintained by the manufacturer.

We **WILL NOT** and **DO NOT** accept responsibility for any overall system performance when factors, such as these, are beyond our control.

**⚠️ WARNING** The entire machine safety system must be tested at the start of every shift. Machine testing should include: (1) proper machine operation and stopping capability; and (2) verification of proper installation and settings of all point of operation guards and devices before the operation is released for production.

## Warning on Actuating Press Valves

**⚠️ WARNING** Control Reliability requires that all Press's use only monitored DUAL SAFETY VALVES for the CLUTCH and monitored DUAL SAFETY VALVES on the BRAKE systems. Never operate a Press that uses a monitored DUAL SAFETY VALVE system on the CLUTCH but not the BRAKE (or vice versa). Dual Safety Valves used on press clutch/brake applications must be rated by the manufacturer for use on press clutch/brake applications.

# Table of Contents

---

Introduction	
System Overview .....	1
Specifications .....	1
System Installation	
Resolver Mounting .....	3
Controller Mounting .....	3
System Wiring .....	3
Dimensional & Wiring Drawings	
• Chain Driven Resolver Installations .....	5
• Resolver Dimensions & Wiring (#28-100) .....	6
• Internal Wiring Diagram (#28-111) .....	7
• Control Box Dimensions (#28-112) .....	8
• Panel Cut-Out Dimensions (#28-113) .....	9
• Control Panel Dimensions (#28-114) .....	10
• External Wiring Diagram (#28-115) .....	11
• Control Board Terminal Chart (#28-117) .....	12
• I/O Board Terminal Chart (#28-118) .....	12
Function Descriptions	
Operator Interface .....	13
Main Screen .....	14
Time-Based Brake Monitor .....	15
Counter .....	17
Servo Feed .....	18
User Settings (Language) .....	19
Press Utility .....	20
Limit Switch .....	21
Die Input .....	22
DIE Type MOM Cycle Skip optional feature .....	22
System Setup & Faults	
System Setup Procedure .....	24
Fault Codes .....	25
Regulations & Guidelines for Safe Operation .....	27-31

# Introduction

## System Overview

The PressCam 8 Junior is a resolver-based press automation controller that incorporates a programmable cam limit switch, timed-based brake monitor, servo control, four counters, and a die protection system. The PressCam 8 Junior is controlled by a 16-bit computer that constantly checks the resolver for accuracy.

### Features

- All six Limit Switch Outputs can be set to cycle (non-timed) two times per crank rotation by setting an open / close crank angle.
- The last three outputs can be set for timed, non-timed, delayed and hold or cycled two times per crank revolution.
- Two additional outputs are for E-Stop faults, sensor faults, motion or brake faults. These outputs use force-guided relays (Form B Safety).
- The first six outputs are small, high-speed, high-capacity relays.
- Brake and die sensor inputs are optically coupled and can be either AC or DC (sourcing or sinking).
- Up to 100 Jobs can be saved using nonvolatile memory chip. The memory chip is removable for ease of transfer. Each Job Number stores a name and/or number up to ten characters for easy identification (seven characters for Limit Switch and Die Input names).
- Built-in Brake Monitor will issue a warning when the programmed warning time is exceeded and will issue a failure signal when programmed stop time is exceeded.
- True Motion Detection system that checks for lack of motion (Motion Fault) and unintended motion (Drift Fault).
- SPM Indicator (Strokes per Minute).
- Crank angle shown graphically and in large numbers.
- Speed compensation of user selected outputs.
- Servo feed setup.
- Stroke, Batch, Quality, and Part Counters to keep track of operation.
- Password and/or Supervisory Controlled Selector Switch to prevent altering of parameters, except for the counters.
- PCLink (off-line Job Programmer) to allow offline job storage and creation.

## Specifications

### Input Power

3 Voltage Ranges:

24VDC (optional)

120VAC (standard)

240VAC (optional, jumper selectable)

All AC voltages work with 50 or 60 Hz

10 watts with all relays on

### Fuses

I/O board

F1 to F8	LS Outputs	5A fast blow (20-023)
F9 to F15	Die Inputs	5A Fast Blow (20-023)
F16	Power	1A Slow Blow (20-022)
F17	24VDC	5A Fast Blow(20-023)

### Computer

F1 Power 5A fast blow (20-023)

### Indicator

Computer Vacuum Fluorescent 4 line by 20 characters  
-5V (GRN) D10

I/O Board

8 Optically coupled inputs (RED):  
Power ON D22  
Brake D21  
Die 1-6 D15-D20

6 LS Outputs (GRN)  
LS1-6 D1-D6

### Set Points

STROKE COUNT:	0 to 999,999	strokes
BATCH COUNT:	0 to 999,999	strokes
QUALITY COUNT:	0 to 999,999	parts
PART COUNT:	0 to 4	parts/stroke
	0 to 999,999	parts total
BATCH SIZE:	0 to 999,999	strokes
Limit switch angle:	0 to 359	degrees
Limit switch timer:	0 to 9999	milliseconds
Die sensor angle:	0 to 359	degrees
Speed Compensation	0 to 99	degrees
MIN SPEED:	0 to 999	SPM
MAX SPEED:	0 to 999	SPM
Brake WARNING:	1 to 999	milliseconds
Brake FAILURE:	1 to 999	milliseconds
Brake ACTUAL:	1 to 999	milliseconds
		(+/-1 millisecond accuracy)
MOTION:	0 to 5.9	seconds (1/10-sec increments)
DRIFT:	preset to 2	SPM (1/10 SPM increments)
Crank Angle:	0 to 359	degrees (1° increments)
SPM:	0 to 999	strokes/minute (+/- 1 SPM accuracy)



**Resolver**

+/- 1° Resolution up to 600 RPM (+/- 2° Resolution from 601 to 1000 RPM)

Shaft loading: Radial 400 lbs., Axial 200 lbs.

Standard cable 30' (maximum length of 600')

**Construction***Stand Alone Unit*

All 18 gauge painted steel NEMA 12 (7¼" w x 9" h x 3¼"d) lockable box with sealed front panel (see "Dimensional Information" in *System Installation* section).

*Panel Mount Unit*

All 18 gauge painted steel NEMA 12 with gasket around edge. (6 ½" w x 7 1/8" h)

(see "Dimensional Information" in *System Installation* section).

**Temperature Range**

0 to 50°C

**Dimensions**

See *System Installation* section.

**⚠ WARNING** The entire machine safety system must be tested at the start of every shift. Machine testing should include: (1) proper machine operation and stopping capability; and (2) verification of proper installation and settings of all point of operation guards and devices before the operation is released for production.

### NOTICE

- When using step down or isolation transformers, make sure to ground one side to prevent the Neutral from floating above ground and causing the surge suppressors (MOV's) to short out.
- The resolver cable must be kept away from high current and/or high voltage lines, or run in its own conduit to prevent excessive noise from causing nuisance faults to occur.
- All remotely wired switches, buttons, etc. must use shielded cable and be kept away from high current and/or high voltage to prevent nuisance faults.
- Do not bring a wire from the "GND" terminal (J4) out to your machine. The J7 jumper connects the "GND" to the earth ground, so you can use the machine itself as the ground.

## Resolver Mounting

The resolver may be driven directly through a Lovejoy coupler, gear and chain, or timing belt.

If a chain or belt is used, it must be set for a 1:1 ratio. Clockwise or counter clockwise rotation can be setup by changing the lead configuration. Bring the press up to top dead center and set the new top dead center (see "Press Utility" in *Function Description* section of this manual for instructions).

Refer to Drawing #28-100 for Resolver Dimensions & Wiring as well as Drawing #28-111 for Internal Wiring at the end of this section.

## Controller Mounting

**Control Box Mount.** If the location has vibration, you must shock mount the box to prevent damage. Four mounting holes are all that is necessary to mount the box (see Drawing #28-112 for Dimensional Layout and Drawing #28-111 for Wiring Diagram in this section).

**Panel Mount.** If you purchased a PressCam 8 Junior without its own enclosure then you must find a location on your control cabinet that will handle the 6"w x 7"h x 3"d panel. If the controller is to be on a door, make sure that when the door is opened nothing will come into contact with the Vacuum Fluorescent Display. Mounting the unit closer to the hinge is probably a good idea for wire routing. Cut out a hole in your control cabinet and drill eight mounting holes. Insert the PressCam 8 Junior into the hole and install the eight #6 keps nuts. Refer to Drawing #28-113 for Panel Cut-Out Dimensions, Drawing #28-114 for Control Panel Dimensions, and Drawing #28-111 for Internal Wiring on the following pages.

## System Wiring

1. Make sure the I/O Board (P1) is plugged into the Computer Board (P2).
2. Install the Resolver Cable between Resolver and J5 of the Computer Board.
3. Install RUN/PROG keyswitch cable (Red and Black) on J2 and Green and Green on J3 of the Computer Board.

See Drawing #28-111 for Wiring Diagram in this section.

**Power Input.** Power for the entire PressCam 8 Junior system is brought in through connector J4 on the I/O Board. The standard voltage input is 120VAC, but 24VDC and 240VAC are optional. See Drawing #28-115 for the External Wiring Diagram in this section.

### Die Inputs (1-6)

- All inputs used are optically coupled and can be either 12 to 24VDC or 120VAC (optional). The voltage type must be selected before hand.
- All inputs are setup for 12 to 24VDC except for the brake/clutch input which is setup for 120VAC.
- Terminals 1 to 6 are Die Sensor Inputs and use the terminal just to the right of 6 as their common.
- Tie the common terminal to the +24VDC terminal of J4 for systems with sensors that go to ground when closed.

Example: Connect the output from all die sensors to Terminals 1 to 6, then connect +24VDC from J4 on the I/O Board to the COM terminal (just to the right of Terminal 6 on the I/O Board).

See Drawing #28-115 for External Wiring Diagram in this section.

### LS Outputs (1-6)

- There are six Limit Switch Outputs.
- Determine the output logic you need for your press control (i.e., Sinking, Sourcing, AC).
- All terminals are DRY and provide you with simple N.O. and/or N.C. switches. You can place any voltage and current (up to 1/2 the relay rating) on the terminals.

See Drawing #28-115 for External Wiring methods in this section.

### Fault Outputs (7-8)

Both of these force-guided relay outputs should be placed either in series with the ESTOP or STOP circuit of your machine or each relay output separately should go to there own STOP circuit. Either relay must be able to shut down machine operation.

See Drawing #28-115 for External Wiring and Drawing #28-116 for Terminal Chart in this section.

### Chain Driven Resolver Installations

#### **CAUTION**

Normally the Resolver is mounted at one end of the Press Crank Shaft and directly driven 1:1 through a Coupler.

If it is not possible to directly couple the Resolver to the Crank Shaft, and you are forced to use a Chain, you MUST follow the guide below:

- 1) You **MUST** install a Resolver “Spring Plate” device PN# 39-149 with a “Chain Break” microswitch wired in series with your STOP or ESTOP circuit.
- 2) The Chain & Sprocket must keep the Resolver and Crank Shaft 1:1 (PN# 52-308 Chain & Sprocket)
- 3) You will probably need to install an idler pulley along the chain to take up slack and bounce in the chain that may cause Faults during operation.



(Below) Shown with Resolver mounted to the Spring Plate:



# SAFETY INSTRUCTIONS

## System Installation

### Resolver Dimensions & Wiring (#28-100 R3)

Dimensions in inches

For millimeters multiply x 2.54

Note: Rev3 diameter shaft is from 9/2015 forward. Rev2 is up to 9/2015.

### CAUTION

For Chain driven Resolvers, you MUST Install Chain Break detection, please refer back to page 5 for installation requirements.

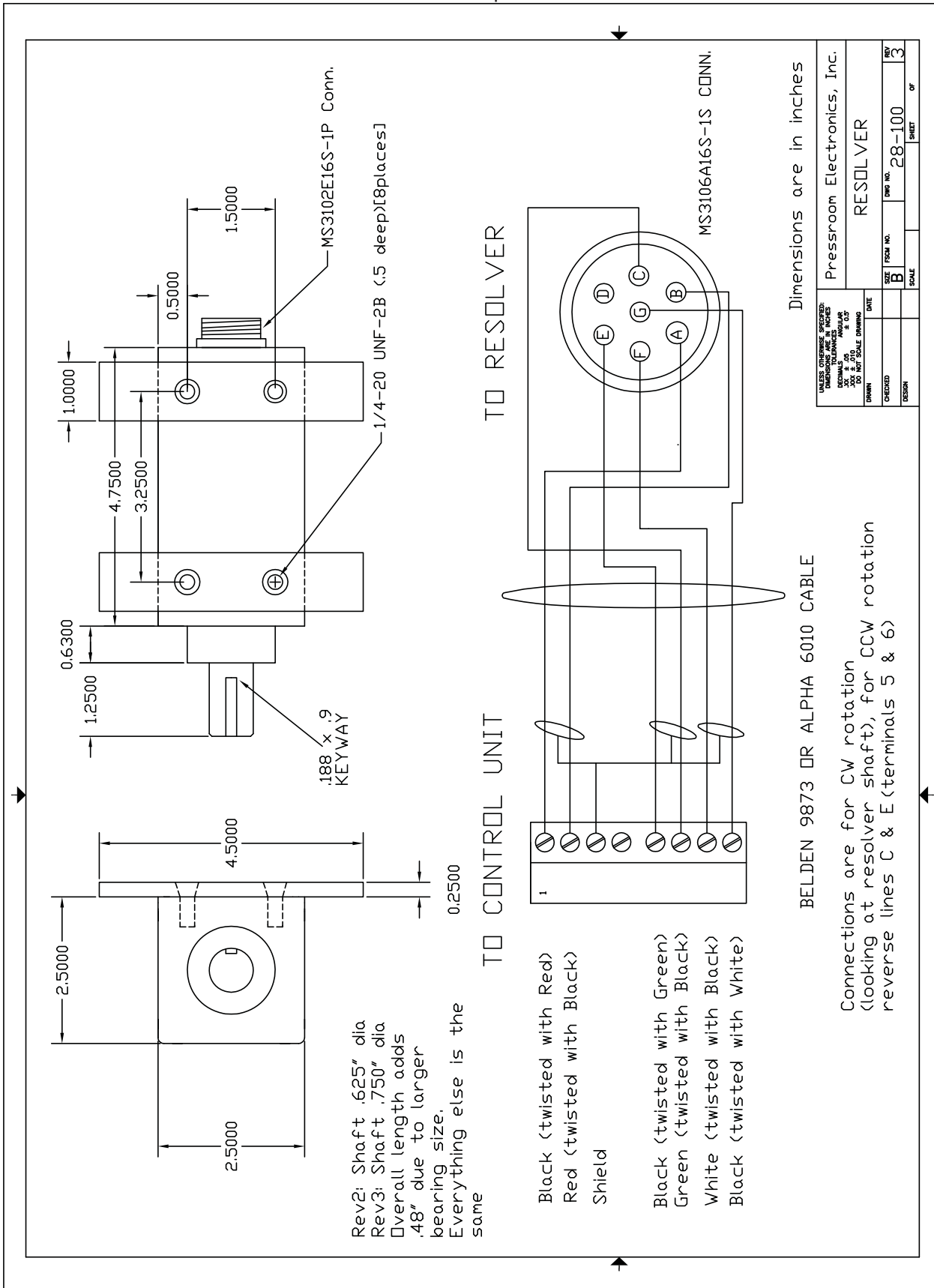

Internal Wiring Diagram (#28-111)

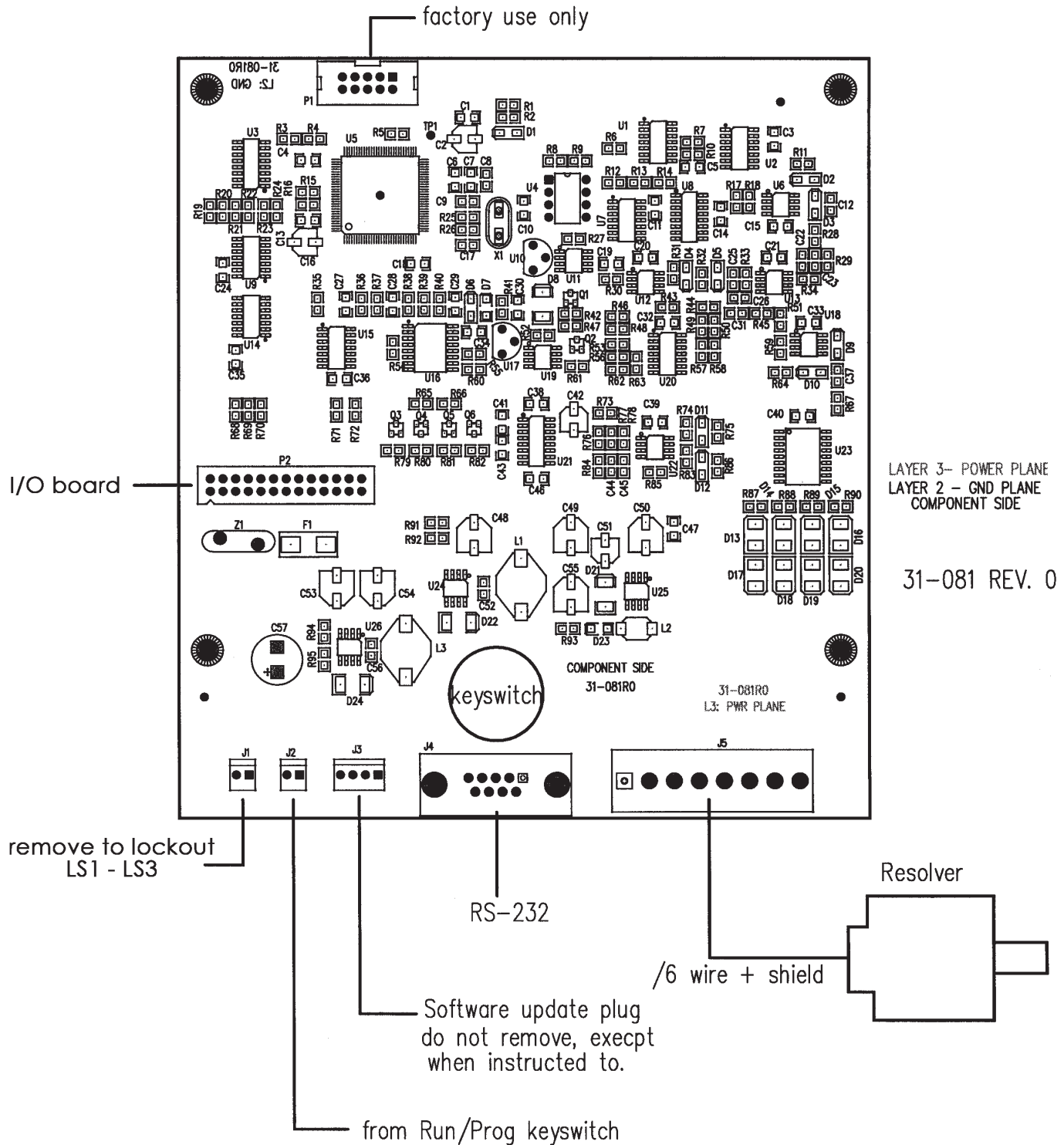

Control Box Dimensions (#28-112)

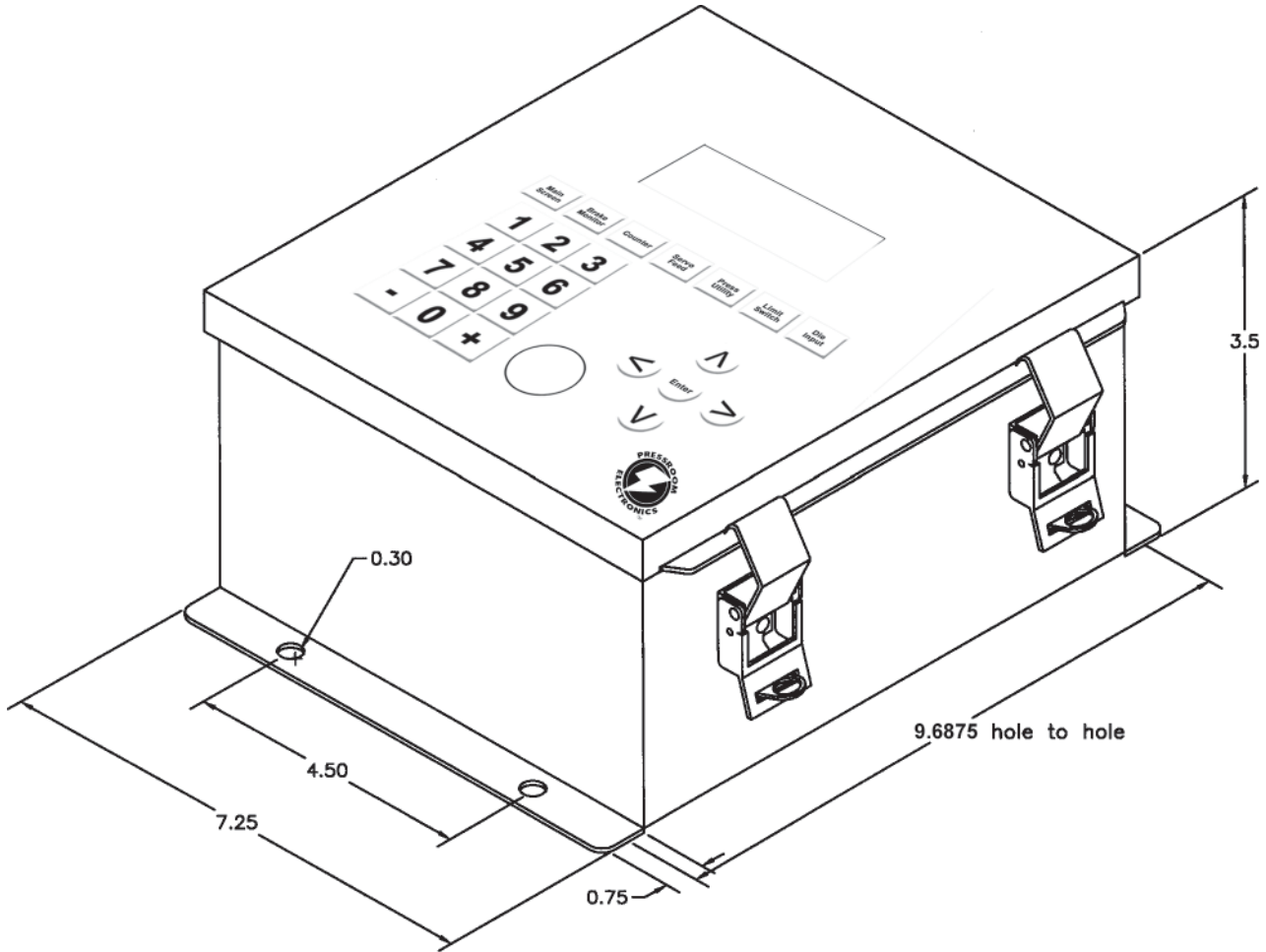

## Panel Cut-Out Dimensions (#28-113)

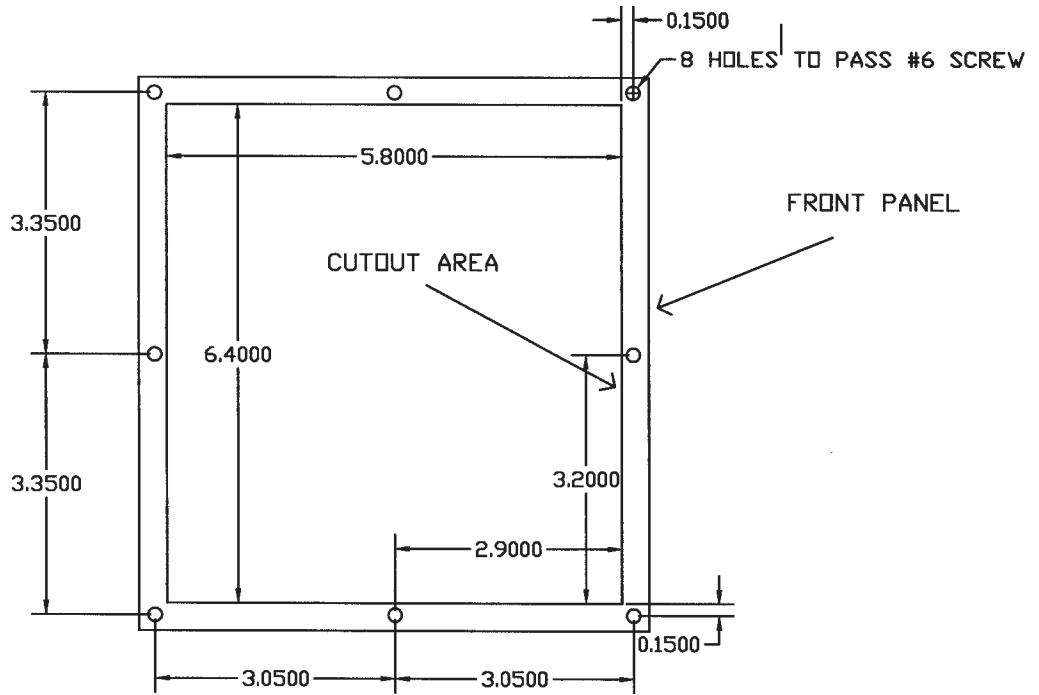



Control Panel Dimensions (#28-114)

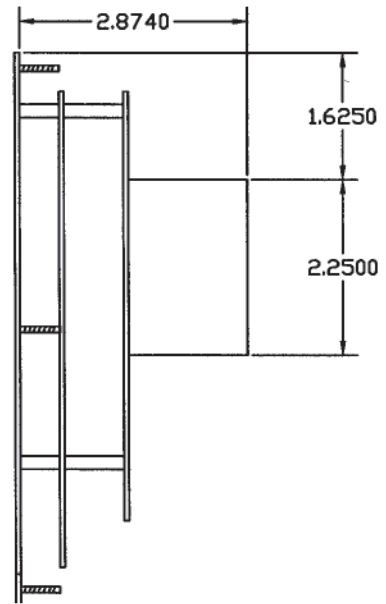
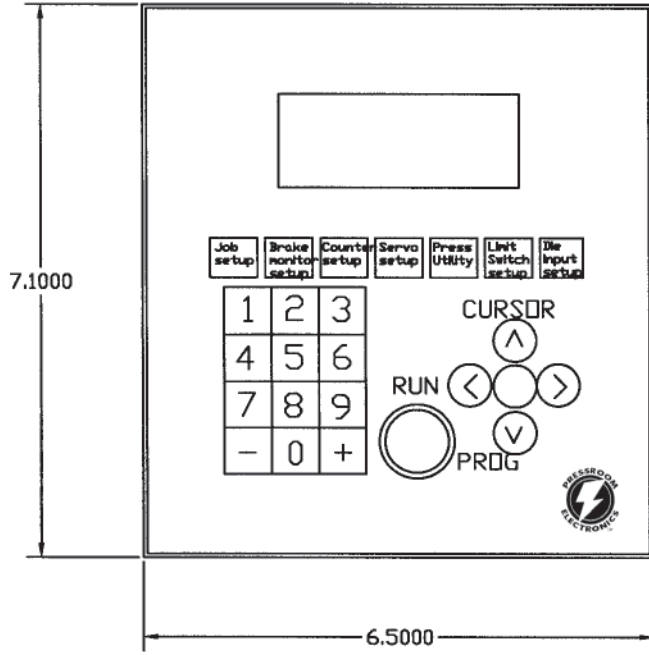

## External Wiring Diagram (#28-115)

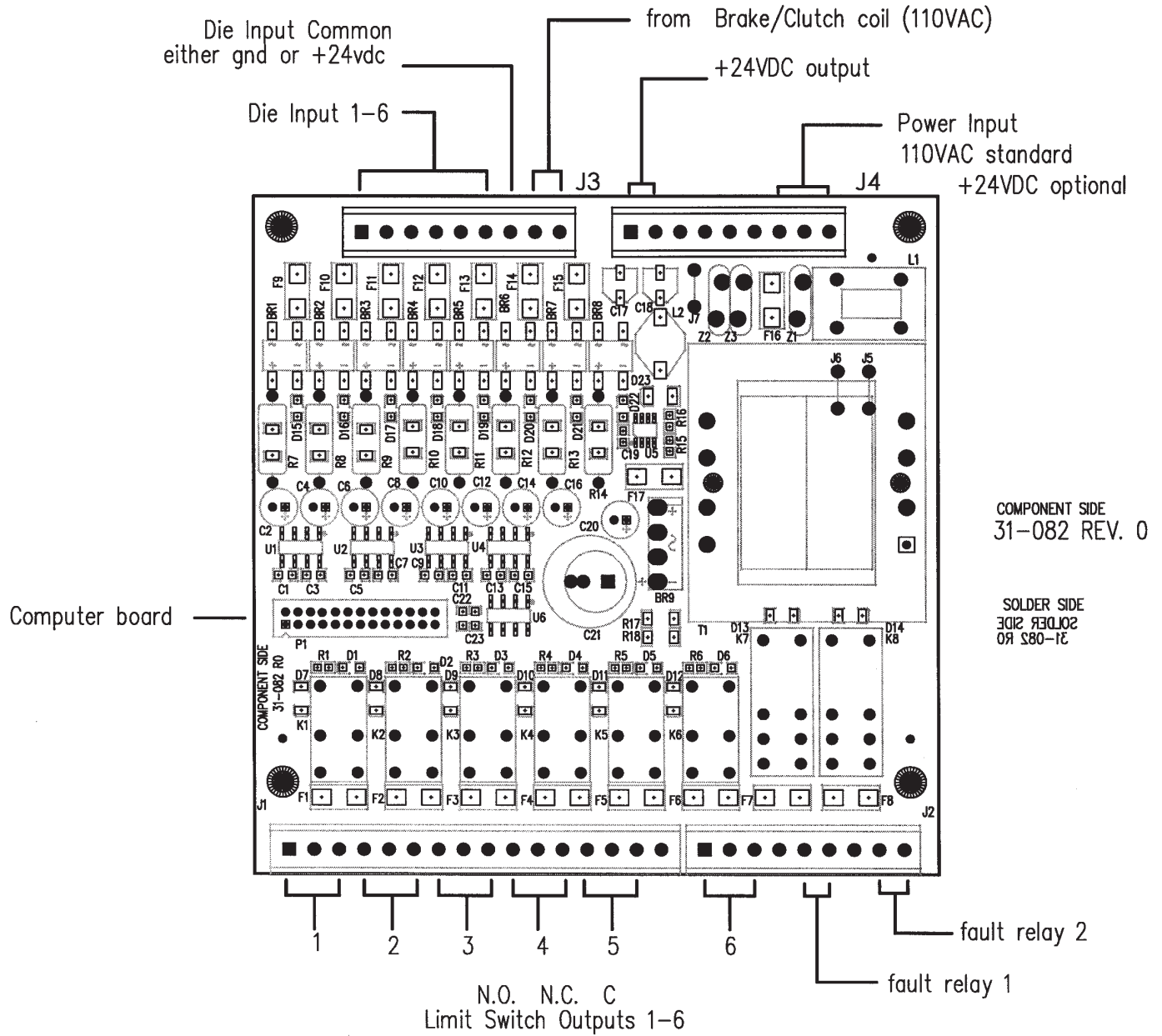

**WARNING**

The 24vdc output (at the top of this board) should not be used to power external devices.

Drawing too much current (Amps) may cause the JOB MEMORY to fault and reset.

If this happens you must use your own 24vdc supply to power your devices.

Computer Board Terminal Chart (#28-117)

Resolver	J11	Connection to resolver	See Resolver #28-100 for details
RS-232 serial	J8	Serial port for Servo control And Software Updating	Standard DB-9 female
BDM	P2	Factory use only	Do not touch
Computer to I/O	P1	Power and I/O	Links both boards
Lock out	J5	ON=lockout LS1-LS3	Pin 1 (right) Green
Keyswitch	J6	From keyswitch	Do not remove Pin 1 (right) Black Pin 2 (left) Red
Software update	J4	ON=normal operation OFF=for updating firmware	Do not remove unless told by factory

I/O Board Terminal Chart (#28-118)

Outputs #1-6	J1-J2	Limit Switch 1 –6 Dry contacts (up to 120VAC)	Up to 2 output windows. LS4- LS6 can be delay/hold or timer based
Outputs#7-8	J2	General Fault output	Open up upon any fault condition including die fault
Inputs#1-6	J3	Die protection 1-6 (24vdc input)	Static, Maintained, Momentary. Sinking or Sourcing
Common	J3	Common terminal for die1-6	Tie to +24vdc for Sinking die inputs. Tie to ground for Sourcing die inputs
Inputs#7	J3	Clutch/Brake input 7 (120vac input)	Parallel signal from clutch/brake valve.
+24vdc output	J4	Unregulated 24vdc output	For use with die inputs only
Power Input	J4	Standard 120VAC input	
I/O to Computer	P1	Power and I/O	

# Function Descriptions

## Operator Interface

The PressCam 8 Junior has a keypad, menu, and cursor buttons for easy navigation and operation.

After wiring is complete, power up the system and make sure the Red LED (D22) on the I/O Board is lit up. Look at the Vacuum Fluorescent Display, the first screen shows the software version number and any optional installed software.

**Run/Prog Keyswitch.** In RUN mode you are not allowed to alter any parameter or change JOB's.

In RUN mode, you are only allowed to clear counters and reset die sensor faults.

When in PROG mode the Die Faults do not open up the fault relays. This is to allow die setup. All other faults will cause the Fault relays 7-8 to open. If the password feature is enabled, you must first enter in the three digit password in order to pass into the PROG mode and be allowed to change parameters.

**⚠ WARNING** In PROG mode, the die inputs can fault out but will not shut down your machine. You can only run ten cycles in PROG mode.

To program, the programmer must have the Supervisory Controlled Key and the PROG mode must be selected. The programmer has the capabilities to do all items that the operator has capabilities of, plus the following:

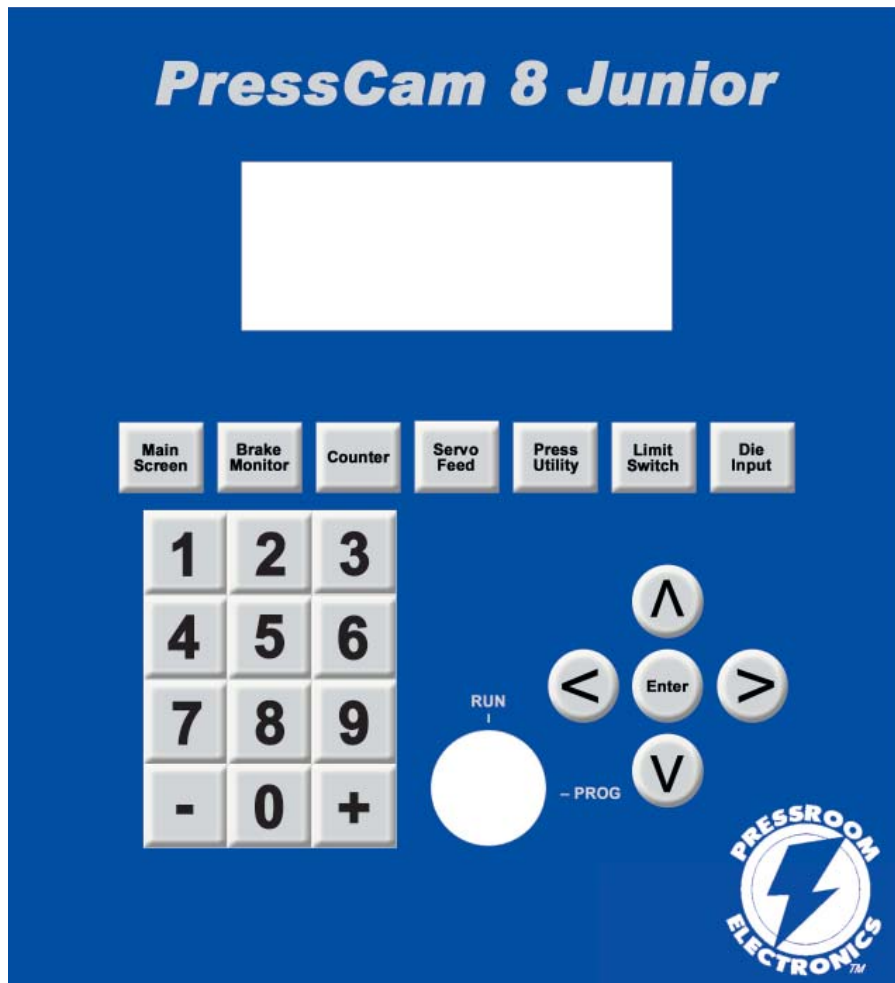

## Main Screen

```
Job: 00
  Parts: 000000
 Batches: 000000
Angle: 000 SPM: 000
```

The Main screen allows for Job Selection and Naming, Parts and Batch Count (see COUNTERS section for descriptions), current press angle, and current press speed.

### NOTICE

To reset the Counters from the RUN MODE you must go to the Counter Screen. You cannot access any function from of the “Main Screen” from the RUN mode.

You can reset die faults from this screen.

**Job Selection.** All jobs (new and old) use only one Top Dead Center offset value. You never have to adjust the SETTDC offset once it is initially set.

**Job Number (must be in PROG mode).** The PressCam 8 Junior has a total storage capacity of 100 jobs. The Job Number displayed indicates which Job Number is currently being run or selected.

1. Move the cursor over the Job Number.
2. Use the - / + keys till the Job Number desired is present and press the “Enter” button.

The PressCam 8 Junior is now ready to run the Job Number that you have selected.

**Job Name (must first select a job number).** The Job Name can consist of up to ten characters. These characters can be alphanumeric and may also include symbols such as /, \, !, ?, =, etc....

1. Move the cursor over to the Name field.
2. Use the - / + keys till the proper letter is found (or the numeric keypad for the proper number).
3. Use the cursor keys to move from character to character.
4. Hit the “Enter” button when finished.

**Parts.** This field displays the number of parts produced since last reset. To reset this counter in RUN MODE, you must go to the “COUNTER” screen, move the cursor to the “Parts” field and hit “Enter” (see COUNTER section for details). In PROG MODE you can reset this field from this screen.

**Batch Count.** The Batch Counter is used to indicate the number of batches completed. To reset this counter in RUN MODE, you must go to the “COUNTER” screen, move the cursor to the “Batch Size” field and hit “Enter” (see COUNTER section for details). In PROG MODE you can reset this field from this screen.

### NOTICE

Batch Counter only works when Part Count is wired to a sensor and is activated.

### Time-Based Brake Monitor

In RUN mode you get a new screen (shown below) that shows only Last Stop Time (in mSEC) and Last Dwell angle (in degrees).

```
Last Stop Time= 000  
  
Last Dwell° = 000
```

In the PROG mode (shown below), you see the original screen (as before) but with the Dwell angle added to the bottom line of the screen.

```
Warn= 000 Fail= 000  
Motion Det= 0.0 sec  
90° - 270° test  
Dwell= Time= 000
```

The PressCam 8 Junior is a time-based brake monitor as opposed to a position-based brake monitor. It does not know or care when the press comes to a stop but rather how long it takes for the press to stop from the time the brake/clutch signal is removed.

This screen shows “Warning” and “Failure” setpoints, “Motion” detection setpoint, Last Stop time, and 90° / 270° stop time checking features.

Monitoring the stop time allows you to determine a safety distance for placing electronic guarding equipment and to shut down the press should the press take longer to stop than allowed for in your safety distance. Refer to the *Regulations & Guidelines for Safe Operation* section in this manual for the safety distance formula as well as the manual that came with your electronic guarding equipment.

The brake monitor function will automatically prevent a successive stroke of the press if the stopping time deteriorates beyond the brake FAIL set-point. The keyswitch is the only way to clear this fault. A brake warning (WARN) set-point is also provided as a notification before the press brake must be repaired.

The PressCam 8 Junior stores only one WARN and FAIL set-point set, therefore, you must set these for the worst case situation (heaviest tool, fastest speed, and 90° stop test).

**Determining the WARN and FAIL Set Points.** The Failure set point is the stop time value that you have just determined above and will use in your safety distance equation (this equation should be found in the manual of

all equipment used to activate or guard your equipment). This value includes the variance factor discussed above to allow for a certain amount of wear in the brake before you have to change it. The larger the failure set point, the further back your guarding equipment will have to be from the pinch point.

**⚠ WARNING** Do not set the failure set-point so large as to allow the press to stop at the top but slide forward down to the pinch point. Your press control should have a position-based monitor to prevent that situation from occurring.

*For example:* If you calculate a stop time of 140msec, but your press varies a little and you want to allow for brake wear so you use a failure stop time of 230msec. The variance factor is then 90msec. The 230msec should be used as your press stop time in calculating your safety distance. Set your warning set point at some value below 230msec to let you know that you are approaching the failure point ahead of time.

**Input Signal.** The brake/clutch signal should be tied to J3 of the I/O Board. For example, if you are running a 120VAC system, run a line parallel from the brake/clutch signal back to the PressCam 8 Junior. There should be 120VAC across the brake/clutch input when the brake is released.

See Drawing #28-115 for External Wiring Diagram in this section.

#### WARN and FAIL Set Points

1. Insert the maintenance key and turn the keyswitch from RUN to PROG (enter the password when asked).
2. Hit the “Brake Monitor” button and use the cursor to select the Warn or Fail fields.
3. Enter in value on keypad or - / + keys.

**⚠ WARNING** Brake Warn and Fail setpoints need to be setup for every Job. Each Job memory will save its own Warn and Fail setpoints.

**Motion Detection.** The PressCam 8 Junior needs to see motion within the time period selected or a fault will occur (lack of motion). Set this value to the minimum value that does not generate a fault. This will enable it to detect faults faster.

You can only use the - / + keys to change this value.

**Drift Detection (not displayed).** The PressCam 8 Junior has built in Drift Detection. If the press starts to move without a brake/clutch signal, a drift fault will occur. The threshold is .2 spm and cannot be user altered.

**90° Stop Test.** Inch the press up to top. Select this feature and hit the “Enter” button. Now, run the press. The PressCam 8 Junior will shut down when the press reaches 90°. The press will come to stop at some point after. This shows the worst case stop time.

**270° Stop Test.** Inch the press up to top. Select this feature and hit the “Enter” button. Now, run the press. The PressCam 8 Junior will shut down when the press reaches 270°. The press will come to stop at some point after. This is for counterbalance setup.

# Function Descriptions

## Counter

```
Strokes: 000000
Parts: 000000 /1
Batch size: 000000
Quality: 000000
```

**NOTICE** All counters are automatically stored at power down.

When Limit Switch #6 output is set to 0 angles but the Speed Comp (sc) is activated, the Batch Counter will trip LS6 when incremented. You must hit the Counter Button to open LS6

The PressCam 8 Junior provides four types of counters: Stroke, Batch, Quality, and Part. When programmed properly a counter will increment each time a part is ejected from the machine. When the programmed value is met, the controller will initiate an action.

**Stroke Count.** The Stroke Counter is used to indicate the total number of strokes that has occurred since the last stroke counter reset. This number increases by one every time the resolver passes 180° regardless of job changes or faults. You can reset this count in RUN or PROG modes.

**Part Count.** Note: This field is also viewed from the “Main Screen” but can only be reset from the “Counter” screen while in RUN MODE.

This box has two fields— (The left hand side) a *Part Increment* field which represents the number of parts produced per stroke, and (the right hand side) a *Part Count* field which shows the number of parts produced. You can only set the *Part Increment* field in PROG mode.

The programmer can set the number of how many parts are being counted or produced on each stroke of the press. They can set the unit to count 0 through 4. If the unit is set to zero, then the PressCam 8 Junior will not increment the Part Count, Batch Count or the Quality Count.

You can reset the *Part Count* in RUN or PROG modes.

## NOTICE

To use an external sensor to increment the part counter, set the “diatype” for DIE#6 to “CNT” and set a start/stop window to check for the external signal (I.E. IF the part will eject at 270°, then set the DIE#6 input window to start=260°, stop=280°), this will now increment the parts counter only when a pulse is properly detected within the DIE#6 window. - To increment the part counter every machine stroke, make sure the “diatype” for DIE#6 is NOT set to “CNT”. The part counter will run internally and you can use DIE#6 for standard die checking.

The Part Increment field is used by the Batch and Quality counters. Resetting the Part Counter will not affect the other counters.

**Batch Size.** The Batch Size determines when the Batch Count increments. This can only be changed in PROG mode. The Batch Size is based on the Part Increment field size (the right hand side of the Part counter field).

In RUN MODE, this field will reset the Batch counter.

**Quality Count.** The Quality Counter is used to stop the machine when the parts produced reaches the value in the “Quality Count.” This is used to indicate to the operator that the last part should be checked for quality purposes based on your company’s SPC requirements. Arc (1-359°)

**Top Stop Angle.** This feature allows you to connect the Counter LS6 output in series with your machines STOP circuit to achieve a Top Stop. The 2nd Press Utility screen allows you to setup a Top Stop Angle where the LS6 output will turn OFF (OPEN) when the Batch or Quality count is reached. The minimum Top Stop Angle is 190deg.



## Servo Feed

```
Speed 1-100: 000
Accel 1-100: 000
MPC 1-100: 000
Feed Len.: 000.000
```

(Can be viewed only while in PROGRAM mode)

Servo control is done through the J4 COM1 port on the PressCam 8 Junior.

PressCam 8 Junior RS-232 DB-9 Pin out

1	do not connect
2	TX, to servo
3	RX, from servo
4	do not connect
5	Digital Ground
6	do not connect
7	do not connect
8	do not connect
9	do not connect
CASE	Chassis Ground

The only pins used the PressCam 8 Junior are 2,3, & 5.

Pins 1,6,8 are tied to +15v, and pins 5 and 9 are tied to ground

Each Job stores individual Servo Setup information and outputs through the RS-232 J4 COM1 port every time you power up the controller, change Jobs, or exit from the Servo Setup screen.

Available Servo Control Protocols:

### **Indramat (comes standard)**

Speed (1-100%)  
Feed Length (0 – 999.999 )

### **Indramat Block Transfer CLM**

Speed (1-100%)  
Feed Length (0-999.999)

### **Indramat OPTI feed**

Speed (1-100%)  
Acceleration (1-100%)  
Feed Length (0-999.999)

### **Rapid-Air S32H**

Speed (1-100%)  
Acceleration (1-100%)

Feed Length (0-999.999)  
Max SPM (0-999)  
Pilot Release (always set to 1)

Automatic Feed Advisor will program the Speed and Acceleration for you when you enter or change Arc or Feed Length values. If the max SPM, ARC, or Feed Length numbers generate Speed/Acceleration numbers that are beyond the Servo's capabilities, the Speed and Acceleration values are set to 0 (note: the Feed Advisor only computes new Speed/Acceleration values when you change Arc or Feed values).

### **P/A industries ultra advantage feed systems SFI**

Speed (1-100%)  
Acceleration (1-100%)  
Feed Length (0-999.999)

### **COOPER-WEYMOUTH PETERSON SERVOMATIC I**

Speed (1-10)  
Feed Length (0-999.999)

### **COOPER-WEYMOUTH PETERSON SERVOMATIC II**

Speed (1-10)  
Feed Length (0-999.999)

### **Co-Press**

Speed (1-100%)  
Acceleration (1-100%)  
MPC (1-250 10tens of seconds)  
Feed Length (0-999.999)

### **Dallas Industries**

Speed (1-100%)  
Acceleration (1-100%)  
Feed Length (0-999.999)

---

# Function Descriptions

## User Settings

This screen can be reached by pressing the “Servo Setup” button two (2) times.

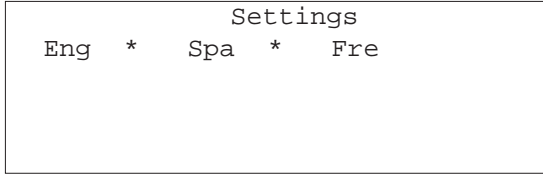

Language: English Spanish French

Use the cursor and enter key to select which language you wish to use.

# SAFETY INSTRUCTIONS

## Press Utility

```
Speed comp: 000
Min= 000 Max= 000
ClrJob SetTDC
PCLink Password 000
```

(Cannot view this this screen from the RUN mode.)

**Speed Compensation.** As the press speeds up beyond its original set point, certain outputs may not respond fast enough to keep up with the increased speed of the press. Also, stop time increases as the press speed increases and therefore the Top Stop signals (LS1 and LS2) will need to be compensated in order for the press to stop on top. Outputs that the user selects for speed compensation will occur sooner (in angular position) as the press speed increases from the minimum speed to maximum speed. When setup correctly, the press will come to a stop on top at any speed between the minimum and maximum set points. Each Job has its own Speed Compensation set point and can be turned off simply by setting the value to 0°.

The user can select which outputs you want to have Speed Compensation by going to the Limit Switch Setup screen and selecting the "\*" for the appropriate outputs in the "sp" column.

### NOTICE

The Speed Compensation value is the amount of compensation that will occur only when the press is operating at the maximum speed set point. As the press slows back down (i.e., brake applied), the amount of compensation is linearly reduced down to 0 (when the press is operating at minimum speed). If the press is run at below minimum speed, there is also no compensation.

### Steps:

1. Set the Speed Compensation set point to 0° (this turns off the function).
2. Set the press Minimum Speed and Maximum Speed set points to the slowest and fastest operating speeds, respectively.
3. Go to the Limit Switch Setup screen and setup the output windows and run the press at the minimum speed. Adjust windows for correct operation at this speed only.

Now you should have a correctly operating press running at minimum speed.

4. Cycle the press at maximum speed. Note the angle where it stopped. Enter the angle at which the press came to a stop (something past 0° in the Speed Compensation field). If the press came to a stop at 30°, then enter this value into the field.

## Function Descriptions

5. Go back to the Limit Switch Setup screen and turn on Speed Compensation for top speed signal outputs (usually LS1 and LS2) by selecting the "\*" in the "sp" column.
6. Operate the press at maximum speed again and check for proper stopping position. Adjust the Speed Compensation angle (up or down) accordingly to force the press to stop on top.
7. Go back (one more time) to the Limit Switch Setup screen and select all the LS outputs you wish to have speed compensation on by selecting the "\*" in the "sp" column.

**WARNING** If the press is stopped during a normal cycle (not at top stop), it is possible that a Speed Compensated Output will trigger again as the press starts to move again to finish the current cycle. This is because you are now starting from 0 SPM and the stopped press location may have not reached the true output angle for the compensated output. If you are using a servo feed initiate, you may have to turn it off before you return back to top stop to prevent a possible double feed.

**Minimum Speed.** Minimum Speed is used by speed compensation and if the press speed exceeds the minimum and then drops below, a fault will occur.

**Maximum Speed.** Maximum Speed is used by speed compensation and if the press speed exceeds the maximum a fault will occur.

**Clear JOB (CLRJOB).** Erases the entire currently selected job. You must hold in the Enter key for two seconds.

**Top Dead Center (SETTDC).** This allows you to zero the press when the Ram is at TDC. Start by inching the press up to TDC. Then hold in the Enter key for five seconds.

**WARNING** This function should only be used during installation or when hardware changes. Never change TDC to fix a timing problem or any other problems with limit switches.

**PCLink (PCLINK) (off-line Job Programmer).** This feature puts the PressCam 8 Junior into a mode that allows the serial port to communicate with the PCJUNIOR.exe Windows-based software (provided on CD). Install the CD onto any Windows machine. Make sure the PC and the PressCam 8 Junior are connected before running the PCJUNIOR or enabling the PCLINK function on the PressCam 8 Junior. Now you can backup, transfer, save, add, delete, and modify job data between your PC and multiple PressCam 8 Junior's.

**Set Password (SETPAS).** The operator enters a three digit number to be used as a password when the key switch is moved from RUN to PROG mode. Set to 000 to turn off the password feature. If you forget your password, contact the manufacturer.

# Function Descriptions

## Limit Switch

This is where LS1-LS6 are controlled.

A unique name (consisting of 7 characters) can be created for each limit switch while viewing the monitor screen (in PROG mode only). However, the setup screens will only show the names LS1 to LS6.

1. Insert the supervisor key into the switch and turn from RUN to PROG mode (enter password if asked).

The following screen is the first screen in PROG mode and the only screen in RUN mode. It monitors the status of all six relay outputs LS1-LS6 as well as displays the current crank angle. An asterisk next to the LS indicates the output relay is energized.

LS1	LS4
LS2	LS5
LS3	LS6
ANGLE: 000	MONITOR

2. Select the JOB you wish to setup (see "Job Selection" in this section).
3. Hit "Limit Switch" button to select LS1-LS3. Hit again to select LS4-LS6.

## Cyclical Outputs

	S	CLS-OPN	CLS-OPN
LS1	000-000	000-000	
LS2	000-000	000-000	
LS3	000-000	000-000	

	S	CLS-OPN	CLS-OPN
LS4	000-000	000-000	
LS5	000-000	000-000	
LS6	000-000	000-000	

Outputs LS1-LS6 can have up to two limits (open/close). Closed segments take precedence over opens, so if you overlap a closed segment on top of an open segment, the output will stay closed.

4. Use the cursor keys to select the proper Limit Switch output field.
5. Select whether you want this output to be Speed Compensated. To select Speed Compensation, hit "Enter" while in the "s" field and an "\*" will appear. Hit "Enter" again and it will disappear to deselect Speed Compensation.
6. Select the proper Close (on), and Open (off) values (up to two sets per output).

## Cycle Delay & Hold Outputs

	DLY CY	HLD CY
LS4	000	000
LS5	000	000
LS6	000	000

Outputs LS4-LS6 can be delayed for a specific number of press cycles and then held on for a specific number of cycles. Selecting the Delay or Hold fields erases all other data for the selected Output (use this for Lubrication, etc.).

Hit "Limit Switch" button until you see "DLY CY HLD CY" heading at the top of the screen. Then select the number of delay cycles (off) and hold cycles (on).

**NOTICE** All cyclical data for LS4-LS6 will be erased if you enter data on this screen.

## Timed Outputs

	STRT ANG	HLDmSEC
LS4	000	0000
LS5	000	0000
LS6	000	0000

Outputs LS4-LS6 can be set to turn on at a specific angle and then hold for a specific time period. Selecting the Hold Time output field erases all other data for the selected Output. The Hold Time is in milliseconds (i.e., 1000=1 sec, 500= 1/2sec).

Hit "Limit Switch" button until you see "STRT ANG HLDmSEC" heading at the top of the screen. Then select the Starting angle (on) and Hold time (in milliseconds).

**NOTICE** All cyclical data for LS4-LS6 will be erased if you enter data on this screen.

## Combining Cycle Delay with Hold Timer

If you enter in a Delay Cycle value and a Hold Timer value, the designated output will turn on at the timer setpoint angle only after the specified number of delay cycles.

# Function Descriptions

## Die Input (3 screens)

A unique name (consisting of 7 characters) can be created for each die sensor (SEN1-SEN6) while viewing the monitor screen (in PROG mode only). However, the setup screens will only show the names SEN1 to SEN6.

In PROG mode you can rename SEN1 thru SEN6 by moving the cursor over the proper SEN field and using the + / - keys to select letters, and the number pad for numbers.

SEN1	*	SEN4	F
SEN2		SEN5	*
SEN3	f	SEN6	

The Die Status Screen (shown above) allows you to run the press and see when a particular sensor is active (closed) and/or faulted, relative to the press angle. A "\*" indicates an active (closed) sensor that has not faulted. A "F" indicates an active (closed) sensor that has faulted. A "f" indicates a non-active (open) sensor input that has faulted. A " " indicates a non-active (open) sensor that has not faulted. This will display in both RUN and PROG modes.

**⚠ WARNING** In PROG mode, the PressCam8 Junior will not shut down, but will limit you to 15 cycles of the press. Also, die faults will not display as a flashing fault message, that only occurs in RUN mode.

Die input #6 is used with the Parts Counter (see the Counter section note).

Hit the "Die Input" button again to select SEN1-SEN3. Hit again to select SEN4-SEN6.

	TYPE	STP	BGN END
SEN1	MOM	E	000-000
SEN2	MOM	E	000-000
SEN3	MOM	E	000-000

	TYPE	STP	BGN END
SEN4	MOM	E	000-000
SEN5	MOM	E	000-000
SEN6	MOM	E	000-000

**How to Turn Off a Die Input:** Select Momentary and 0° for both open/close angles.

**Die Fault STP type:** Select whether you want a Die input sensor fault to E-stop (select E), or Top-stop (select T) the machine. An E-Stop will open the two fault relays on a Die fault. The fault relays should already be wired in series with your E-stop(s) circuit(s). A Top-stop will turn on PLS#5 only! You will need to wire PLS#5 N.O. contacts in series with your controllers Top-stop circuit. PLS#5 must have the Speed comp \* turned on, and the angles must be set to 0°, otherwise the fault relays will drop out instead. The default is to E-stop the machine.

**NOTICE** The Top-stop feature is only available on 31-081REV2 (or higher) Junior display boards.

**Top Stop Angle.** This feature allows you to connect the Die TSTOP LS5 output in series with your machines STOP circuit to achieve a Top Stop. The 2nd Press Utility screen allows you to setup a Top Stop Angle where the LS5 output will turn OFF (OPEN) after a TSTOP Die Fault occurs. The minimum Top Stop Angle is 190deg.

## DIE Type MOM Cycle Skip Optional Feature

Standard Junior Units with a Die Input set to MOM require a pulse (transition) within a set window every press cycle; otherwise a fault will occur (Estop or Tstop).

The "MOM Cycle Skip" feature prevents a fault from occurring as long as a pulse (transition) occurs within a set window, within a set # of press cycles, otherwise a fault will occur (Estop or Tstop).

**NOTICE**

- 1) This will only work with Die#1 thru Die#3
- 2) Once a pulse is detected, the internal counter resets to 0
- 3) Changing Jobs will reset the internal counter to 0
- 4) Changing the # of press cycles resets the internal counter to 0

### Setup:

As you select the "DIE TYPE" for a particular DIE input, you cycle through the standard "DIE TYPES": MOM, SNO, SNC, MNO, MNC when you press the "ENTER" key

But now you will see MOM, SNO, SNC, MNO, MNC, #1, #2, ... #24, #25, then back to MOM

The #1 through #25 are all of the "DIE TYPE" MOM The # is the # of press cycles the MOM die type is allowed to miss seeing a pulse (transition)

# Function Descriptions

**To program a die sensor**, you must first understand the five types of sensor windows that we use.

1. *Momentary Inputs (MOM)* - The die input must see a change of state from the sensor somewhere within the programmed window. The change can be open to closed or closed to open and may occur multiple times within the same window. No change of state within the window will cause the PressCam8 Junior to fault.
2. *Maintain N.O. Inputs (MNO)* - The die input must not see a change of state from the sensor from the beginning of the window through the end of the window. The signal must also be open. If a signal is received from the sensor while in the window, the PressCam8 Junior will fault.
3. *Maintain N.C. Inputs (MNC)* - The die input must not see a change of state from the sensor from the beginning of the window through the end of the window. This signal must also be closed. If no signal is received from the sensor while in the window, the PressCam8 Junior will fault.
4. *Static N.O. Inputs (SNO)* - This type of input is typically used for Buckle Detection. Being static means that it should never see a signal from the sensor anytime. If a signal is seen, the PressCam8 Junior will fault. This type of input works 360° of the press rotation.
5. *Static N.C. Inputs (SNC)* - This type of input is typically used for End of Stock detection. Being static means that it should see a signal from the sensor at all times. If a signal is not seen, the PressCam8 Junior will fault. This type of input works 360° of the press rotation.
6. *Counter (CNT)* - This type is allowed only for DIE#6 and is used to select how the parts counter gets its signal to increment. This type acts exactly like the “Momentary” type except the parts counter increments when a change of state occurs within the selected window. (see the Counter section for details).

## **CAUTION**

In software version 2.1a (and above), the “maintained” die die sensor function checks outside the window for a transition. If no transition is detected when the “maintained” window is reached, a die fault occurs. Older software does not check outside the window, you may wish to run the same die sensor to a second die input and set it to check either for a “Momentary” or for an opposite “Maintained” state during some other portion of the cycle (i.e., Die #1 Maintained N.C. 180 to 270, Die #2 Maintained N.O. 50 to 120, both Die #1 and #2 inputs tied together).

**How to Program a Die Input.** Ensure that the unit is in PROG mode.

## **WARNING**

The Screen does not update if you are currently changing a Begin or End angle. New or changed information is stored in nonvolatile memory as soon as the entire value is entered.

When in PROG mode, all die-input sensors are active and working, however, the press will not stop due to a die fault. All input faults are bypassed in the PROG mode.

With the unit in PROG mode,

1. Use the cursors to select the Die Input Sensor you want to program.
2. Hit the “Enter” key to cycle through the Sensor Types.
3. Cursor left when you have finished selecting the Type.
4. Enter the Beginning and Ending angles for Die Window.

# SAFETY INSTRUCTIONS

## System Setup Procedure

**WARNING** Make sure that GF 1 and 2 outputs #7 and #8 are installed in series with your ESTOP circuit. These outputs open up in the event of a fault in the PressCam 8 Junior.

1. Install and verify proper internal system wiring. Refer to Drawing #28-101 in the *System Installation* section.
2. Install and verify proper external system wiring (i.e., power, die inputs, limit outputs, fault outputs).
3. Power up the system and push any key to get past the Start Up screen.
4. Remove the J1 security jumper (backside of Vacuum Fluorescent Display by the keyswitch).
5. Turn the keyswitch from RUN to PROG mode and select the Press Utility button. Select the Password field. Enter a new password to prevent unauthorized altering of job data (the password will remain on the screen until you leave this).
6. Select Job 1 and enter a new name (up to ten characters with the exception of Limit Switch and Die Input names where the limit is seven characters).
7. Select the Minimum and Maximum Speed fields and enter in the speed range of the press for this particular job.
8. Inch Press up to Top Dead Center.
9. Select "Press Utility" button and select SETTDC. Hold in the "Enter" key for five seconds to zero the resolver angle (**Do Not perform this setup unless the press is at Top Dead Center!**)
10. Follow the instructions for the time-based brake monitor function and select the 90° Stop Test field. The press will now travel 90° past top and stop. The ACTUAL stop time can now be used to calculate the WARN and FAIL stop time values as well as help determine proper safety distances for press guarding equipment.
11. Select the MOTION field and enter in a value slightly larger than the time it takes for the press to start moving once it gets the signal to move.
12. Set up the Counter fields for the particular job.
13. Select the Limit Switch Setup field. Select the proper open /close windows to satisfy your press control inputs (LS 1-6). Select the hold time for the timed outputs (LS 3-6).
14. Cycle the press, check the press control, adjust the Limit Switch Outputs. Repeat this step until all outputs are correct.
15. Set up Speed Compensation (if running variable speed).
16. Select the Die Sensor Setup field. Select which input(s) are static and the proper start / end window for the cyclical die inputs (inputs #1-6).
17. Return back to the main PROG mode screen and cycle the press. Watch the Die Sensor screen for faults. Repeat step 16 until faults disappear.
18. Turn the keyswitch back from PROG to RUN mode and replace the J1 security jumper. You are finished.

**NOTICE** To clear fault code(s) you must switch from RUN to PROG mode and hit the "Enter" key.

# System Setup & Faults

## Fault Codes

### 10 CYCLE LIMIT

*Cause:* Press cycled ten times while in PROGRAM mode.

*Cure:* Hit "Reset All Faults."

### BATCH LIMIT REACHED (NOT DISPLAYED)

*Cause:* The Part Count field reached the Batch Size setpoint causing the counter output to drop out.

*Cure:* Push the Enter key to reset in either RUN or PROG modes. Batch Count will increment unless you use the arrow keys to move the cursor over that field and clear it.

### BELOW MIN SPEED

*Cause:* The press (after three cycles) was below the Minimum Speed setpoint.

*Cure:* 1) Make sure resolver is coupled 1:1.  
2) Check your press.  
3) Lower setpoint.

### BRAKE FAULT

*Cause:* Press ACTUAL stop time exceeded the FAIL time.

*Cure:* Fix the press brake.

### BRAKE WARNING

*Cause:* Press ACTUAL stop time exceeded the WARN time.

*Cure:* Fix the press brake.

### CHECKSUM FAILURE

*Cause:* Data stored in nonvolatile ram or the data transfer to/from the slave has been corrupted.

*Cure:* 1) Excessive electrical noise.  
2) Computer failure.

### DIE SENSOR FAULT #

*Cause:* Die Sensor table will display all faults.

*Cure:* 1) Press had die fault.  
2) Angle window for sensor is incorrect.  
3) Check that unit is receiving the signal from the sensor.

### DRIFT FAULT

*Cause:* The press moved faster than 1 SPM when the "control" was not signaled to move. (i.e. no clutch signal)

*Cure:* 1) Check that the LED on the I/O Board for the brake/clutch input is lighting up when the brake is released.  
2) Value set in DRIFT may be too low and

the press may be vibrating from nearby machinery.

- 3) Examine brake, clutch, and valves on the press.
- 4) Resolver miss-wired or bad.

### FEATURE NOT AVAILABLE

*Cause:* The selected feature cannot be accessed at the present time.

- Cure:* 1) Reset any faults you have.  
2) Remove the J1 security jumper.

### LACK OF MOTION

*Cause:* The press showed no motion within the MOTION time period setpoint.

- Cure:* 1) Check that the resolver is linked to the crank shaft properly.  
2) The setpoint may be too low and not allowing enough time for the press to start moving.

### MAX SPEED FAULT

*Cause:* The press was going faster than the Maximum Speed setpoint.

- Cure:* 1) Make sure resolver is coupled 1:1.  
2) Check for press.  
3) Lower setpoint.

### MEMORY CORRUPTION

*Cause:* Internal computer RAM is corrupted or data coming from the slave CPU has been corrupted.

*Cure:* 1) Excessive electrical noise.

### MOVING BACKWARDS

*Cause:* While in RUN mode the press move backwards. This fault will not occur in PROG mode.

*Cure:* If press is moving forward, then check the resolver wiring at the Master and Slave board connections. Hit Enter to reset fault.



### POWERING DOWN

*Cause:* Occurs when the 120VAC that powers the PressCam 8 is removed. Current data is saved and system locks up to prevent data from being corrupted.

*Cure:* 1) Check power input to Presscam 8. Especially if you are using 24VDC. Your supply may not be able to handle the load.  
2) Consult factory.

### QUALITY CHECK LIMIT REACHED

*Cause:* The Part Count field reached the Quality Count setpoint causing the Counter Output to drop out.

*Cure:* Push the Enter key to reset in either RUN or PROG modes. Part Count field will reset to 0.

### RELAY OFF S/B ON

*Cause:* Output #7 or #8 relay detected off but should be energized (on)

*Cure:* 1) Excessive electrical noise.  
2) Bad relay.  
3) Faulty circuitry.

### RELAY ON S/B OFF

*Cause:* Output #7 or #8 relay detected energized, but should be off.

*Cure:* 1) Relay contact welded closed.  
2) Excessive electrical noise.  
3) Bad relay.  
4) Faulty circuitry.

### RESOLVER FAULT 1 OR 2

*Cause:* The angle reading is not stable and/or skipped.

*Cure:* 1) Bad connection in either end of the resolver cable.  
2) Miswired resolver cable.  
3) Excessive electrical noise.  
4) Faulty resolver and/or circuitry.

### SLAVE FAILURE

*Cause:* The slave computer is not sending valid data back to the master.

*Cure:* 1) Excessive electrical noise.  
2) Computer failure.

### SPM > 999

*Cause:* Unit is only designed to operate up to 999 SPM. If you are not operating outside this range, then there is a fault in the system.

*Cure:* 1) The resolver is faulty.  
2) Excessive electrical noise.  
3) Computer failure.

# Regulations & Guidelines for Safe Operation

## SAFETY INSTRUCTIONS

### American National Standards Institute (ANSI)

#### B11.1-2009

#### 6.3.2 Presence-sensing Point of Operation Devices

A presence-sensing point-of-operation device, if used, shall protect the operator and others and shall be interfaced with the control circuit to prevent or stop slide motion if the operator's hand or other body part is within the sensing field of the device during the closing portion of the stroke. In addition:

- (1) Presence-sensing devices shall not be used for safeguarding the point of operation on presses using full-revolution clutches.
- (2) When the sensing field has been interrupted, use of the normal press stroke initiating means shall be required after clearing the sensing field to resume press operation.
- (3) Muting (bypassing of the protective function) of the device shall be permitted after the hazardous portion of the press stroke has been completed. Muting of the device shall be accomplished in such a manner that no single component failure shall prevent the normal stop command but shall prevent subsequent press strokes until the failure is corrected.
- (4) The device shall have an identifiable minimum object sensitivity so that an obstruction of an equal or greater size will be detected anywhere within the sensing field regardless of the plane of intrusion.
- (5) The device shall have a maximum response time which shall not be affected by object sensitivity adjustments or environmental changes.
- (6) The devices which require adjustments to accommodate variations in ambient or operating conditions or which incorporate channel blanking or floating window features shall be designed so that the adjustments or features are capable of being supervised by the employer.
- (7) The presence-sensing device shall be provided with a means that visibly indicates when it is and is not in use and functioning properly. The device shall also indicate which sections, if any, have been blanked out.
- (8) The device shall not fail to respond to the presence of the operator's or other's hand or body part due to the presence of a reflective object or work piece.

- (9) The device shall be designed and constructed so that any single component failure, including output devices, shall not prevent the normal "Stop" command from being sent to the press, but shall prevent operation of the press stroke until the failure has been corrected. In the event of a power failure to the device, it shall initiate a "Stop" command to the press-control system.
- (10) The device and the press-control system shall be interfaced so that the device's "Stop" command shall initiate stopping action during the closing portion of the press stroke. The interface shall be designed to ensure that a single component failure within the interface of the control system shall not prevent the normal "Stop" command from being sent to the press, but shall prevent operation of the press stroke until the failure has been corrected.
- (11) The device's sensitivity to intrusion shall not be adversely affected by changing conditions around the press.
- (12) The effective sensing field of the device shall be located at a distance from the nearest point-of-operation hazard so that the operator or others cannot reach into the point of operation with a hand or other body part before cessation of motion during the closing portion of the stroke.
- (13) The device shall not be affected by ambient light or by light-source decay so that the increase in response time or object sensitivity is greater than the value used to calculate the safety distance.
- (14) All areas of entry to the point of operation not protected by the presence-sensing device shall be otherwise safeguarded.
- (15) When a device is used on a press in a single-stroke mode and when the protection of the operator is dependent upon the stopping action of the press, a stopping performance monitor shall be required.



# SAFETY INSTRUCTIONS

## B11.19-2010

### 6.3.5 Two-Hand Control Device

- (3) Each operator hand control shall be located at a distance from the point of operation so that the operator cannot release either hand control and reach into the point of operation prior to die closure or prior to cessation of slide motion during the closing portion of the stroke.

Below is the formula for calculating the safety distance of a light curtain or palm buttons. The machine stop time should be measured with the machine running at its fastest speed with its heaviest die or tooling and the stop time being measured at the 90° position in the downstroke. The following formula should be used when calculating the safety distance:

$$DS = K \times (TS + TC + Tr + Tbm)$$

- DS = Minimum safety distance between the device and the nearest point of operation hazard (in inches).
- K = Hand speed constant. This value has been determined by various studies and, although these studies indicate speeds of 63 in/sec to over 100 in/sec, they are not conclusive determinations. The employer should determine this value by considering all factors, including physical ability of the operator.
- TS = Stop time of the machine tool measured at the final control element.
- TC = Response time of the control system. NOTE: TS and TC are usually measured by a stop time measurement device.
- Tr = Response time of the presence-sensing device and its interface, if any, as stated by the manufacturer or measured by the employer.
- Tbm = Additional time allowed for the brake monitor to compensate for variations in normal stopping time.

## Occupational Safety & Health Administration (OSHA)

### 1910.217 (C) (3) (iii)

#### Safeguarding the Point of Operation

- (iii) A presence sensing point of operation device shall protect the operator as provided in paragraph (c) (3) (i) (a) of this section, and shall be interlocked

## Regulations & Guidelines for Safe Operation

into the control circuit to prevent or stop slide motion if the operator's hand or other part of his body is within the sensing field of the device during the downstroke of the press slide.

- The device may not be used on machines using full revolution clutches.
- The device may not be used as a tripping means to initiate slide motion.
- The device shall not be constructed so that a failure within the system does not prevent the normal stopping action from being applied to the press when required, but does prevent the initiation of a successive stroke until the failure is corrected. The failure shall be indicated by the system.
- Muting (bypassing of the protective function) of such device, during the upstroke of the press slide, is permitted for the purpose of parts ejection, circuit checking, and feeding.
- Refer to ANSI B11.19-2010 above for calculating safety light curtain distance from the point of operation.
- Guards shall be used to protect all areas of entry to the point of operation not protected by the presence sensing device.

### 1910.217 (C) (3) (iii)

#### Additional requirements for safeguarding

Where the operator feeds or removes parts by placing one or both hands in the point of operation, and a two hand control, presence sensing device or Type B gate or movable barrier (on a part revolution clutch), is used for safeguarding:

- The employer shall use a control system and a brake monitor which comply with paragraphs (b) (13) and (14) of this section.
- Inspection, maintenance, and modification of presses-
  - It shall be the responsibility of the employer to establish and follow a program of periodic and regular inspections of his power presses to insure that all their parts, auxiliary equipment, and safeguards are in a safe operating condition and adjustment. The employer shall maintain records of these inspections and maintenance work



# Regulations & Guidelines for Safe Operation



- performed.
- (ii) Each press shall be inspected and tested no less than weekly to determine the condition of the clutch/brake mechanism, antirepeat feature and single stroke mechanism. Necessary maintenance or repair or both shall be performed and completed before the press is operated. These requirements do not apply to those presses, which comply with paragraphs (b) (13) and (14) of this section. The employer shall maintain a certification record of inspections, tests and maintenance work which includes the date of inspection, test or maintenance; the signature of the person who performed the inspection, test, or maintenance, and the serial number or identifier of the press that was inspected, tested or maintained.

## 1910.212

**General requirements for all machines (covers press brakes, hydraulic, and pneumatic machines not covered by mechanical power press standards).**

- (a) Machine guarding - (1) Types of guarding. One or more methods of machine guarding shall be provided to protect the operator and other employees in the machine area from hazards such as those created by point of operation in going nip points, rotation parts, flying chips, and sparks. Examples of guarding methods are: barrier guards, two-handed tripping devices, electronic safety devices, etc.

### NOTICE

These are only partial reprints, refer to your Federal Register for total construction, control reliability, and machine guarding requirements for the subject machine being guarded for all applicable OSHA Standards.



## ANSI Standards B11.19-2010

Formula for calculating safety light curtain distance from point of operation.

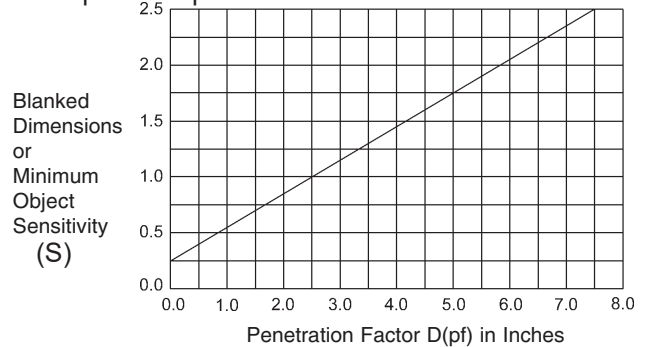

The effective sensing field of the device shall be located at a distance from the nearest recognized hazards such that the operator or others cannot reach the hazard with a hand or other body part before cessation of motion during the hazardous portion of the machine cycle.

The point at which a device responds to an intrusion may vary. The devices should be located or adjusted such that the device always responds to the intrusion at or prior to the safety distance. Care should be exercised when installing the device to ensure that it does not detect false signals from other devices in the area.

Usually the electro-optical presence-sensing device is used in a manner that provides a protected zone in front of the primary work area with auxiliary devices or guards used to protect secondary access areas. In some cases, however, mirrors may be used in conjunction with the device to provide 2, 3, or 4 sided protection.

The machine stop time should be measured with the machine running at its fastest speed with its heaviest die or tooling and the stop time being measured at the 90° position in the downstroke.

The following formula should be used when calculating the safety distance:

$$D_s = K (T_s + T_c + T_r + T_{bm}) + D(pf)$$

$D_s$  = Minimum safety distance between the device and the nearest point of operation hazard (in inches).

$K$  = Hand speed constant. This value has been determined by various studies and although these studies indicate speeds of 63 in/sec to over 100 in/sec, they are not conclusive determinations. The employer should determine this value by considering all factors, including physical ability of the operator.

## SAFETY INSTRUCTIONS

Ts = Stop time of the machine tool measured at the final control element.

Tc = Response time of the control system.

NOTE: Ts and Tc are usually measured by a stop time measurement device.

Tr = Response time of the presence-sensing device and its interface, if any, as stated by the manufacturer or measured by the employer.

Tbm = Additional time allowed for the brake monitor to compensate for variations in normal stopping time.

D(pf) = Added distance as indicated by the chart above. The minimum object sensitivity is stated by the manufacturer. If beam blanking or floating blank features is used, these figures should be added to the object sensitivity figure before using the above chart.

### Machine Control Reliability Requirements

#### Control Reliability:

“...control circuits shall be designed and constructed so that a single failure or fault within the system does not prevent the normal stopping action from being applied to the press when required, or does not create an unintended stroking action, but does prevent initiation of a successive stroke until the failure is corrected.” (ANSI B11.1-2009)

“...control shall be designed to prevent initiation of a stroke signal in the event that a failure occurs within the press control.” (ANSI B11.2-2013)

“Robots shall be designed and constructed so that any single, reasonably foreseeable failure will not cause hazardous motion of the robot.” (ANSI/RIA R15.06-2012)

“...control circuits shall incorporate features to minimize the possibility of an unintended stroke in the event of the failure of the control component to function properly, including relays, limit switches, and static output circuits.” (ANSI B11.1-2009)

“...control system shall be constructed so that a failure within the system does not prevent the normal stopping action from being applied to the press when required, but does prevent initiation of a successive stroke until the failure is corrected.” (ANSI B11.1-2009)

## Regulations & Guidelines for Safe Operation

“...the control system shall be constructed so that a failure within the system does not prevent the normal stopping action from being applied to the press when required, but does prevent initiation of a successive stroke until the failure is corrected.” (OSHA CFR 1910.217)

### Safety Guidelines for Management

#### Operational Safety

1. Appoint a Safety Coordinator to be responsible for safety regulations, requirements, and suggestions. He must review and investigate all accidents and “close calls.”
2. Establish and issue safety rules. Inform each employee of his responsibilities. Make sure he understands them and knows what is expected of him.
3. A thorough review and an early inspection must be made of existing presses, dies, and point of operation guarding to attain the degree of responsibility required by ANSI B11.1-2009 Safety Standards and Federal State laws. Review what mandatory modifications are necessary.
4. Equipment that is no longer safe and cannot be economically upgraded should be destroyed.
5. Never allow persons legally under age to operate or assist in the operation of machinery.
6. All personnel must be properly trained to eliminate accidents and injuries.
7. Regardless of the operator’s experience, education or language barrier, it is the responsibility of the supervisor to give him a thorough explanation with each new job assignment.
8. No employee should be given a work assignment that he does not fully understand. Only properly instructed and thoroughly trained personnel should be assigned to work on or with any machine.
9. It shall be the responsibility of the employer to provide an adequate, clean, safe, and uncluttered work area around each machine.



# Regulations & Guidelines for Safe Operation



10. If a malfunction is reported, stop the machine immediately, correct the problem, then resume production.
11. Investigate all accidents and close calls. Analyze the reason for occurrence. Take action to prevent recurrences. Keep records of the investigation and preventative steps that were taken.
12. Only employees who understand the machines' operation and safety requirements and who are able to communicate this knowledge should be given the responsibility of instructing and training others to perform as operators.
13. Management must decide that personnel protective safety equipment is required to perform each job safely. Items such as safety glasses, shoes, gloves, helmets, hand pads, spats, protective sleeves, and material handling equipment are common in the metal working industry. If noise levels are excessive, protective head sets and ear muffs are recommended.
14. When designing point of operation guarding, the manufacturing process should be weighed heavily in favor of operational safety.
15. Establish safe and convenient material handling methods and procedures.
16. Post in convenient areas the names, addresses, and phone numbers of physicians and hospitals, and members of the organization who are to be called in case of emergency.
17. All equipment must be electrically connected according to the National Electric Code and be consistent with other accepted practices.
18. Provide adequate and proper fire protection equipment.

## Power Press Guarding

1. Press manufacturers do not know and cannot foresee the magnitude of potential applications of power presses. Therefore, only the press user can determine the type of guards that have to be used in order to perform the job safely. It is the responsibility of the user management to make certain that point of operation guarding and other necessary safety devices are installed. The press should be guarded in such a manner that it is impossible for the operators to place their hands or any other part of the body in the die area.

2. The press user should become thoroughly acquainted with the safety devices commonly employed in power press operations.
3. Feeding devices are strongly recommended since they remove the operator from the die area and, therefore, allow more effective utilization of guards and safety devices.
4. Do not release a press for production before installing and testing all guards and covers.
5. Make frequent evaluation checks of all guarding and devices while the press is running. Correct all unsafe findings immediately.

## Power Press Care Through Inspection and Maintenance

1. All maintenance and inspection personnel should be specifically instructed and must understand proper maintenance and inspection procedures contained in this manual.
2. Set up a daily, weekly, and monthly press inspection program. Use a checklist and verify that the job is done correctly.
3. Establish a preventative maintenance program. Records of all maintenance work performed must be kept.
4. Since all equipment has a limited life, quality maintenance personnel are required to obtain maximum usage of your equipment.
5. Releasing a power press for production following maintenance should be the responsibility of a qualified individual assigned by management.
6. To maintain the original level of press reliability, careful inspection of mechanical, electrical, and pneumatic areas must be made. This may give an advance warning of a hazard which then can be corrected to prevent possible injuries and damage.



### Safety Enforcement

In order to have an effective safety program, management at all levels must enforce every safety rule and regulation. Strong disciplinary measures are sometimes required. They should consist of a warning, written reprimand, work suspension, transfer, demotion, or possibly a dismissal. All infractions must be reported and recorded. Once an infraction is noted, it shows that an unsafe practice or condition has existed. This may be the result of poor planning or improper training and instructing. The reason for the infraction should be analyzed in order to take corrective action.

### Supervisor Training

It should be the responsibility of management to instruct their supervisors on safety, giving job instructions, supervising operators, determining accident causes, and building safety attitudes among the machine operators. Accidents can occur due to inadequate training of supervisors.

### Operator Training

It shall be the responsibility of management to insure proper training of operators. A specific training program should be instituted to instruct the operator in safety, proper usage of the equipment, and correct operational procedure in performing each and every job. In addition to the supervisor, the operator should be familiar with the proper guarding of the point of operation. Never permit an operator to start a job without complete instructions from his immediate supervisor.









**[www.pressroomelectronics.com](http://www.pressroomelectronics.com)**

### **WARRANTY**

Manufacturer warrants that this product will be free from defects in material and workmanship for a period of one year from the date of shipment thereof. Within the warranty period, manufacturer will repair or replace such products which are returned to it with shipping charges prepaid and which will be disclosed as defective upon examination by the manufacturer. This warranty will not apply to any product which will have been subject to misuse, negligence, accident, restriction, and use not in accordance with manufacturer's instructions or which will have been altered or repaired by persons other than the authorized agent or employees of the manufacturer.

### **DISCLAIMER**

The provisions of the paragraph "Warranty" are the sole obligations of the manufacturer and exclude all other warranties of merchantability, expressed or implied. Further, there are no warranties which extend beyond the above warranty.

### **DISCLAIMER**

Pressroom Electronics does not assume liability for the contents of this publication or the use of any products described. Pressroom Electronics reserves the right to make changes to the products or any catalogs without further notice.

### **ERRORS AND OMISSIONS**

Information presented by Pressroom Electronics has been checked and is believed to be accurate; however, no responsibility is assumed for clerical, typographical or proofreading errors or omissions.

### **LIMITATION OF LIABILITY**

In the event of any claim or breach of any obligations of manufacturer under any order, whether expressed or implied, and particularly in the event of any claim or a breach of the warranty or warranties contained in the paragraph "Warranty" or of any other warranties, expressed or implied which might, despite the paragraph entitled "Disclaimer," be determined to be incorporated in any order, the company shall under no circumstances be liable for any consequential or special damages, either in law or in equity, or for losses or expenses or claims for the same arising from the use of, or inability to use, the products of the manufacturer for any purpose whatsoever.

### **⚠️ WARNING**

The entire machine safety system must be tested at the start of every shift. Machine testing should include: (1) proper machine operation and stopping capability; and (2) verification of proper installation and settings of all point of operation guards and devices before the operation is released for production.

### **CHANGE IN SPECIFICATIONS**

Product specifications and accessories may be changed at any time based on improvements and other reasons. It is our practice to change part numbers when published ratings or features are changed, or when significant construction changes are made. However, some specifications of the Product may be changed without any notice. When in doubt, special part numbers may be reassigned to fix or establish key specifications for your application. Please consult the factory.



# Pressroom *Electronics*™

## Sales and Marketing Offices

### United States

Pressroom Electronics, Inc.  
P.O. Box 99875  
Pittsburgh, PA 15233  
Toll Free: 800-937-4334  
Direct: 412-262-1115  
Fax: 412-262-1197

### Canada

Pressroom Electronics, Inc.  
8-1734 Orangebrook Court  
Pickering, Ontario L1W 3G8  
Toll Free: 888-285-8885  
Direct: 905-831-1111  
Fax: 905-831-4064

## Customer Service (630) 443-9320

We have designed our equipment to the very highest performance and safety standards known to the current technological state of the art, as evidenced by our U.S.A. and foreign patents issued and pending. However, the installation, usage, suitability, and fitness of our equipment for any purpose, known or unknown, is interdependent upon the performance of other equipment not manufactured, installed, secured or maintained by Pressroom Electronics, Inc.

We cannot and do not accept responsibility for any overall system performance when factors, such as these, are beyond our control.

[www.pressroomelectronics.com](http://www.pressroomelectronics.com)

[sales@pressroomelectronics.com](mailto:sales@pressroomelectronics.com)  
[service@pressroomelectronics.com](mailto:service@pressroomelectronics.com)